



GRF302

Portable filtration rig

User Guide



www.mpfiltri.co.uk

SAFETY WARNING

Hydraulic systems contain dangerous fluids at high pressures and temperatures. Installation, servicing and adjustment is only to be performed by qualified personnel.

Do not tamper with this device.

Contents

1	Introduction	5
2	Specification	8
	<i>•Warranty and Recalibration</i>	
3	Operating Instructions	10
	<i>•Before operation •415V Version Installation •During operation •After operation •Product Maintenance</i>	
4	Filters	15
5	System Cleaning Recommendations	16
6	Six Steps to Better Fluid Handling	17
7	Misuse of product	19
8	Disposal	20
9	Electrical and Hydraulic diagrams	21

1 Introduction

The GRF302 is a mobile filtration unit which is designed for hydraulic fluid cleaning applications. The unit is designed to control particulate contamination to within the defined limits described in ISO4406 and relevant to the filtration size being utilised. This unit is designed for filtration of unpressurised systems by a competently trained engineer or a trainee under supervision with basic knowledge of hydraulic equipment and fittings.

Please Note The GRF302 is designed for use with ISO VG 32 or equivalent mineral oils working at a working temperature of 20°C +. When operating at lower temperatures and/ or using more viscous oils the performance of the unit will be reduced. Please contact MP Filtri UK for details on compatible fluids. We also recommend that the unit is not altered in any way without prior permission from MP Filtri UK - such as the addition of quick release couplings or change of hoses, as this could affect the performance of the unit.

In compliance with Machinery Directive 2006/42/EC

- Pre-filling of housings - Where the housings of hydraulic pumps and motors require pre-filling with fluid prior to start up, a readily accessible and marked means for pre-filing shall be provided and be located to ensure that air is not trapped in the housings.
- Cleanliness level of fluid - The cleanliness level of hydraulic fluids, expressed in accordance with ISO4406, shall be suitable for the most contaminant-sensitive component in the system. Note 1: Commercial hydraulic fluids might not exhibit the required

cleanliness level when delivered. Note 2: Contamination of the fluid can affect the electrical conductivity of the fluid.

- Filling points - All filling points for fluids shall be clearly and permanently marked. Filling points should be fitted with sealed and captive covers to prevent the ingress of contaminants when closed. Contamination during filling shall be prevented by filtration or other means. Where this requirement is not feasible, maintenance and service information shall be provided.
- Filtration - Filtration shall be provided to maintain the required cleanliness level of the hydraulic fluid expressed in accordance with ISO4406. If the required cleanliness cannot be achieved with a main filter system (i.e. pressure or return line filter), a separate off-line filtration system may be used.
- Identification statement (reference to this international standard) It is strongly recommended to manufacturers who have chosen to conform to this International Standard that the following statement be used in test reports, catalogues and sales literature: "Hydraulic systems and their components are in accordance with ISO4413:2010 Hydraulic fluid power - general rules and safety requirements for systems and their components."
This product complies with the BS EN ISO4413:2010 Hydraulic Fluid Power - General rules and safety requirements for systems and their components.

Applications

- Pre-filtering and transferring oil systems
- Filtering and continuous cleaning of systems
- Removal of free water from hydraulic systems¹

¹ For standard 30L/m unit only (spin on type elements).

Benefits

- Extended oil life
- Less frequent oil disposal
- Decrease equipment deterioration
- Improve system productivity

2 Specification

<i>Motor</i>	0.75 kW electric motor with 5 bar bypass across pump
<i>Power supply</i>	Standard options available 110V, 240V and 415V, other supply options are available, please contact MP Filtri
<i>Connection Rating</i>	110V 16A 3 pin, 240V 13A 3 pin BS1363.
<i>Flow rate</i>	30L/min
<i>Control</i>	Electric control box
<i>Indicator</i>	Delivery line visual indicator with combined electric cut out switch to show change of filters is required.
<i>Fluid compatibility</i>	Mineral oil compatible - please contact sales team for queries about other fluids
<i>Hoses</i>	Flexible hoses - 2m long suction and outlet hoses with 1m lances
<i>Mounting</i>	Portable heavy duty trolley and wheels
<i>Inlet</i>	Inlet (pump protection) filtration - plastic washable 173µm
<i>Filtration</i>	Delivery filtration "spin -on" type, bypass set at 1.75 bar. Water removal element available see section 4 for all filtration options
<i>Viscosity</i>	150 cSt maximum fluid viscosity

Ambient working temperature 0°C Min to 35°C Max

Noise 75dB next to unit

Dimensions 860mm(H) x 500mm(W) x 560mm(D)

Weight 55kg with oil in the trolley

As a policy of continual improvement, MP Filtri reserve the right to alter the specification without prior notice.

2.1 Warranty and Recalibration

Warranty The GRF302 is guaranteed for 12 months from date of receipt.

3 Operating Instructions

3.1 Before operation

- Ensure that the operator is wearing appropriate personal protection equipment when operating the GRF302.
- The GRF302 should be situated on a sturdy base and not at an angle.



Figure 1

- Check for any damage to the unit such as a kink in the hoses, product is not to be used if this is the case.



Figure 2

- Check that all fittings are tight.
- Check that the motor voltage corresponds with the supply voltage.
- Check filter element and seal compatibility with the fluid.
- Ensure any anti-whip fixings are securely attached to the drum/reservoir.
- Ensure inlet and outlet hoses are held securely by any anti-whip fixings.
- Ensure the outlet hose is located higher than the inlet hose and sufficient fluid is available.
- The area of operation should be clearly marked; for example with cones.



Figure 3

- The area around where the GRF302 will be operated should be made safe; i.e. any potential hazards removed.
- The operator should identify the location of the isolation of the mains power in case of need for emergency stop.
- The operator should identify the emergency stop of the power supply used, in case of need.

- Please note the operator is responsible for meeting all COSHH requirements when using this product.

3.2 415V Version Installation

With the 415V units the direction of flow needs to be determined to be correct through the pumps and filters.

1. The inlet lance needs to be positioned in the oil reservoir below the level of the oil.
2. The outlet lance needs to be positioned in the oil reservoir above the level of the oil.
3. After the initial operation checks have been completed the unit can be turned on.
4. If there is a flow of oil the GRF302 can be used.
5. If there is no flow then there is reverse flow and the outlet lance is currently acting as the inlet.
6. If this is the case the GRF302 should be moved to a suitable location (after isolating the power supply) and a qualified electrician should swap the cables connected to the L1 and L2 pins in the plug. Then repeat the above checks to test the flow.

Note: Reverse flow through the filters will damage them and they will have to be replaced immediately.

3.3 During operation

- If all checks pass then press the green ‘on’ button.
- Monitor the outlet filter indicator during normal operation and change the element when the visual indicator turns to

red. The unit should be switched off and the power supply isolated BEFORE following the instructions in 'Product Maintenance'.

- See 4 for the recommended filter and duration of cleaning for the required application.

3.4 After operation

- Before stopping the GRF302 pull the inlet hose out of the fluid and allow the pump to clear most of the oil out of the pipes, then stop the pump and isolate the power supply.
- Following this, allow fluid to drain for at least 1 minute and replace the lances in the lance holder before transporting the GRF302 to a new location.
- If a different oil is used, filters should always be replaced- before filters are replaced the new oil should be flushed through the GRF to waste for at least 30 seconds.

3.5 Product Maintenance

Tools required for product maintenance

Specialist Tools: Boa constrictor strap can be purchased from MP Filtri UK (please note this is a filter removal tool only)

MP Part Number: 12.156

Standard Tools Spanners: sizes 37mm and 40mm

- Always switch the unit off and disconnect the unit from its power supply prior to changing the filter elements or opening the control box.
- Using the boa constrictor strap remove the element by positioning as shown in the image below and then rotating in a clockwise direction when looking from above.



Figure 4

WARNING: DO NOT USE BOA CONSTRICTOR TO TIGHTEN FILTER

- Filter to be retightened to hand tight by rotating in an anti-clockwise direction when looking from above.
- Clean up any spilt oil on the unit.
- Hoses are to be replaced as soon as any damage is identified.

4 Filters

Outlet filtration options available:

- CS150 A Series 3, 6, 10 and 25 micron absolute
- CS150 P Series 10 and 25 micron nominal P10 is standard supply for initial filling applications

GRF302 Water removal options available:

- CW150 P series 10 and 25 micron nominal removing 0.79 litres of water while filtering oil at 10 or 25 micron nominal filtration



Figure 1

5 System Cleaning Recommendation

The following table is a guide to typical system cleaning

Typical hydraulic applications Component types	Cleanliness class required		Outlet filter required	
	ISO4406 code	NAS1638	Type	Element types
High performance servo-valves	15/13/9	3	3 micron absolute	A03
Industrial servo-valves	16/14/10	5	3 micron absolute	A03
Piston pumps, proportional valves, compensated flow controls	17/15/11	6	6 micron absolute	A06
Vane pumps, spool valves	18/6/13	7	6 or 10 micron absolute	A06, A10
Gear pumps, manual and poppet valves	19/17/14	8	10 or 16 micron absolute	A10, A16
Ram pumps	20/18/15	9	25 micron absolute	A25

Reservoir capacity (litres)	400	600	800	1000	1200
Cleaning time (hours)	2	3	4	6	8

Notes:

1. The clean up rates are based on an initial contamination level of ISO4406 23/21/19 (NAS1638 Class12).
2. More than one filter element may be required to obtain the cleanliness code stated above.

Figure 1

6 Six Steps to Better Fluid Handling

- Utilising the GRF302 series filtration units

1 Pre-filter new oils before using them

Most new oils are heavily contaminated with dirt and moisture. Regardless of how it is packaged (Bulk or Drums). It must be filtered first through a filtration unit. This single practise alone can reduce contamination significantly.

2 Off-line units can dialysis oils

Most people only use their filtration units to transfer oils, but they should also be used to clean the oil inside hydraulic reservoirs, gear boxes, turbines and other machinery. This is usually called offline, kidney loop or dialysis filtration. This is an extremely effective and simple way to reduce contamination. Make up a schedule, keep your filtration unit in circulation on your equipment, in addition to using it for cleaning new oils and for transferring oil. A portable filtration unit should be every oil handlers primary tool for their job.

3 Make oil handling safer, cleaner and better

A lot of plants and factories have portable filtration units, but they are rarely used to their full potential, due to lack of basic maintenance. If you provide your oil handlers with safe,

clean, easy to use and effective oil handling products, they will use them more. The benefits include more productivity, higher profitability, less labour and part costs, less oil consumption and disposal costs, less injuries and oil spills.

4 Use only absolute rated filter elements

When ordering your filtration unit, request absolute filtration elements. The sole purpose of a filtration unit is to remove as much dirt as possible from the oil. MP Filtri absolute elements are 99.5% efficient, and have greater dirt holding capacity and larger effective filtering area than nominal elements. In short, they will last longer, hold more dirt and filter effectively.

5 Once a year inspect your oil handling equipment

Check the filter indicators are working. Check the hoses for deterioration. Inspect the seals and connections making sure that there are no leaks. Check the mechanical structure to ensure it is in good working order and a piece of equipment your oil handlers will want to use.

6 Regularly sample your oils

Periodic and accurate analysis of your oils will indicate how well the machinery is operating. It indicates what maybe going wrong before the machine breaks down, resulting in loss of production and therefore high costs. After better oil handling has begun and savings realised, it becomes more apparent that frequent and accurate oil analysis is needed.

7 Misuse of product

- The product should be connected to the mains supply and not wired directly to the mains.
- The product is not a pipe cleaning tool and therefore shouldn't ever be connected to a system. It is only to be used in un-pressurised systems.
- Pipes should never be allowed to lie along the floor when the GRF302 is in use.
- During operation the GRF302 should never be left unattended.
- During operation the GRF302 is to remain stationary, it shouldn't be moved. If it is required for the unit to be moved then the pump should be stopped first.
- The operator should follow all standard operating procedures previously set at the operating location as well as the procedures required by the GRF302.
- The GRF302 is not suitable for use in an explosive environment or an ATEX zone.
- Over tightening of filter can damage filter thread causing possible leakage.
- The product is designed to protect itself should it be used outside of its fluid viscosity specification. As such if the viscosity of the fluid is too high the internal breaker will activate and stop the unit from operating.

8 Disposal

- Packaging - All GRF302 products are sent in PVC shrinkwrap and this should be recycled with other plastics.
- Filters and GRF302 - Should be fully drained and disposed of according to EU waste framework directive and ISO44001 Environmental Management.

9 Electrical and Hydraulic diagrams

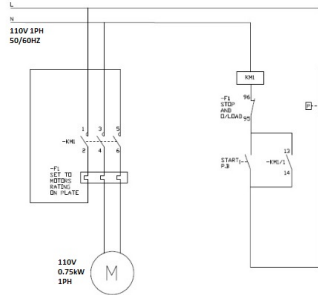
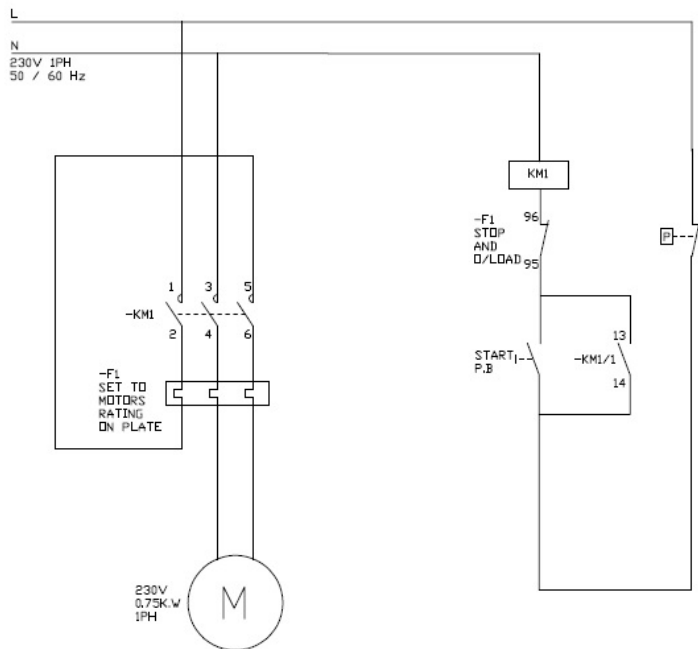

Figure 1 Electrical wiring diagram for GRF302 110V



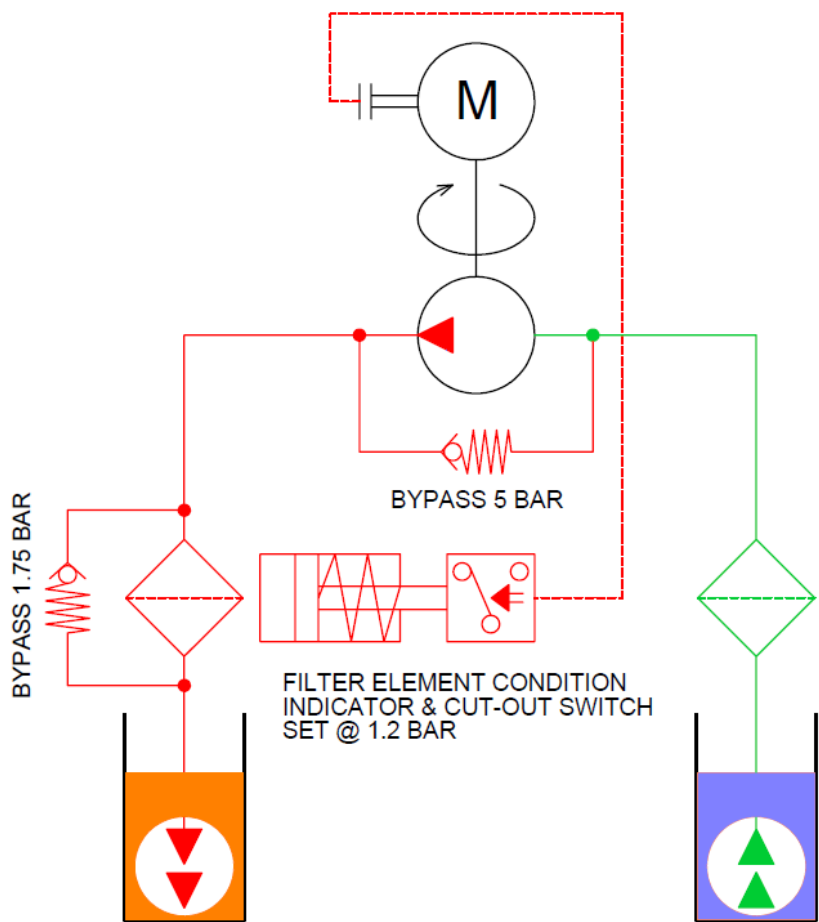

Figure 3 Hydraulic diagram for GRF302

Produced by MP Filtri UK

Revision 3.0

As a policy of continual improvement, MP Filtri UK reserve the right to alter specifications without prior notice.

Except as permitted by such licence, no part of this publication may be reproduced, stored in retrieval system or transmitted, in any form or any means, electronic, mechanical, recording, or otherwise, without prior written permission of MP Filtri UK.

